

## Geräteaufbau / Equipment construction / Budowa sprzętu

### Wachsschmelzgerät / Wax melter / Topielnik Typ 20/30

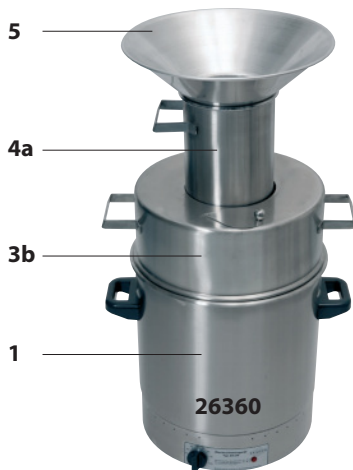

- 1 = Wachsschmelzgerät Typ 20/30 / Wax melter Type 20/30 / Topielnik Typ 20 / 30
- 2 = Einlegerost Höhe 70 mm / Grids insert height 70 mm / Koszyk druciany h=70 mm
- 3a = Lochdeckel / Hole lid / Pierścień centrujący
- 3b = Lochhaube / Hole cover / Pokrywa zbiornika
- 4a = Wachsschmelzgefäß / Wax melting pot / Pojemnik do topienia wosku
- 4b = Seifenschmelzgefäß / Soap melting pot / Pojemnik do topienia mydła
- 5 = Tropfring / Drip ring / Pierścień - Ociekacz
- 6 = Haltezange / Tongs / Uchwyt pojemnika

